



# NZS4541:2007

Brief Outline of Significant Changes  
SFPE Seminar May 2007

# Introduction

- Introduce major changes to the Standard
  - Significant changes to design criteria
  - Significant spatial and coordination requirements
- Warning
  - Each clause was reviewed
  - 1000+ public comments
  - Many small changes
    - Need to relearn the document

# Program

- Two issues re-litigated
  - SSC and Contractor Qualifications
- Public Comment
  - 15 May to 13 July?
- Publication 31 October?
- DBH intend to cite ASAP?

## Useful Tools

- NFPA13
  - Purchase Handbook?
- FM DS 8-1
- FM DS 8-9
- NFPA30
  
- Useful or Minimum if designing and specifying?

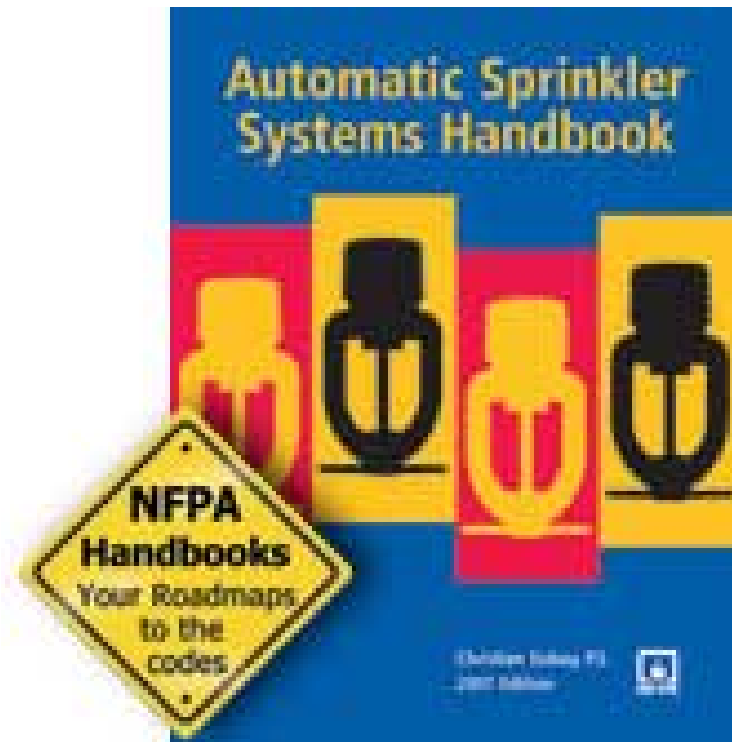

## EHH Rules

- Now based on American Practices
- Major learning exercise
- Very little relationship to old FOC based rules
- Traps?
  - Packaging
  - Flammable Liquids
  - Aerosols
  - Idle pallets
  - **Plastic pallets**

**STORAGE HAS CHANGED...**

**CHALLENGES HAVE CHANGED...**

**SO HAVE WE.**

Tyco Fire Products has risen to meet the challenges of an ever-changing storage industry with the development of the most comprehensive range of storage sprinklers on the market.

Innovative sprinklers such as the EC-25, ESFR-25 and ESFR-17 are just a few examples of our commitment to meet the dynamic challenges of the 21st century.

Regardless of the size of the storage space or the materials it houses, Tyco Fire Products is reaching to new heights to meet any warehousing challenge with sprinkler solutions that work.

**tyco**  
Fire Products

Tyco Fire Products  
800-623-6512  
Fax 216-362-6385  
www.Tyco-Fire.com

# Plastic Buildings

FM Global  
Property Loss Prevention Data Sheets **1-57**  
May 2005  
Page 1 of 18

PLASTICS IN CONSTRUCTION

**Table of Contents**

	Page
<b>1.0 SCOPE</b> .....	2
1.1 Changes .....	2
1.2 Hazard .....	2
<b>2.0 LOSS PREVENTION RECOMMENDATIONS</b> .....	2
2.1 Introduction .....	2
2.2 Plastic Wall and Ceiling Panels .....	2
2.2.1 Construction and Location .....	2
2.2.2 Protection .....	7
2.3 Plastic Skylights/Rooflights .....	9
2.3.1 Construction and Location .....	9
2.4 Other Plastics in Construction Applications .....	10
2.4.1 Construction and Location .....	10
2.5 Miscellaneous .....	11
2.5.1 Human Element .....	11
2.5.2 Ignition Source Control .....	11
<b>3.0 SUPPORT FOR RECOMMENDATIONS</b> .....	11
3.1 Behavior of Plastic Materials in a Fire .....	11
3.1.1 Polyurethane .....	11
3.1.2 EPS .....	12
3.1.3 Thermal Barriers and Metal Skins for Polyurethane, Polyisocyanurate, and EPS .....	12
3.1.4 Plastic Building Panels .....	12
3.1.5 Outdoor Storage Tanks .....	13
<b>4.0 REFERENCES</b> .....	13
4.1 FM Global .....	13
APPENDIX A GLOSSARY OF TERMS .....	14
APPENDIX B DOCUMENT REVISION HISTORY .....	17
APPENDIX C PROPERTIES OF PLASTIC MATERIALS AND FIRE TESTS .....	17
C.1 FM Global Corner Tests .....	17
C.2 Flammability Characterization Test .....	18
C.3 Polyurethane .....	18
C.4 Expanded and Extruded Polystyrene (EPS) .....	18
C.5 Rigid Plastic Panels .....	18
<b>List of Figures</b>	
Fig. 1. Horizontal panel with double tongue and groove joint .....	4
Fig. 2. Single tongue and groove joint .....	6
Fig. 3. Butt-type joint with additional battening .....	6
Fig. 4. Overlap joint with additional screws to secure adjacent panel skins .....	7
Fig. 5. Cooler panel locking joint .....	15
Fig. 6. Typical plastic building panels .....	16
Fig. 7. Typical usage of reinforced plastic building panels .....	17
<b>List of Tables</b>	
Table 1. Protection for Non-FM Approved EPS Core Panels on Walls and Ceiling/Roof <sup>1</sup> .....	9

©2005 Factory Mutual Insurance Company. All rights reserved. No part of this document may be reproduced, stored in a retrieval system, or transmitted, in whole or in part, in any form or by any means, electronic, mechanical, photocopying, recording, or otherwise, without written permission of Factory Mutual Insurance Company.



- Based on FM1-57
- Effectively storage risks
  - 100mm EPS – 15mm/min density
  - >100mm EPS -18mm/min density
- Storage Risks
  - Probably not a big factor
  - Higher densities, lower areas anyway
- Alternatively wall drenchers
- ELH & OH risks
  - Increased densities
    - Not exorbitantly so

# Freeze Protection

- Antifreeze not allowed in storage risks unless specifically listed
  - One system limited to Class 2 Commodities
- Dry and Preaction Systems will become the de facto choice
  - Electronic double interlock for racks?
  - Tyco's vanQuish "surround and drown" system to be released to A/NZ market
    - Hopefully this quarter?
    - Register interest for seminar

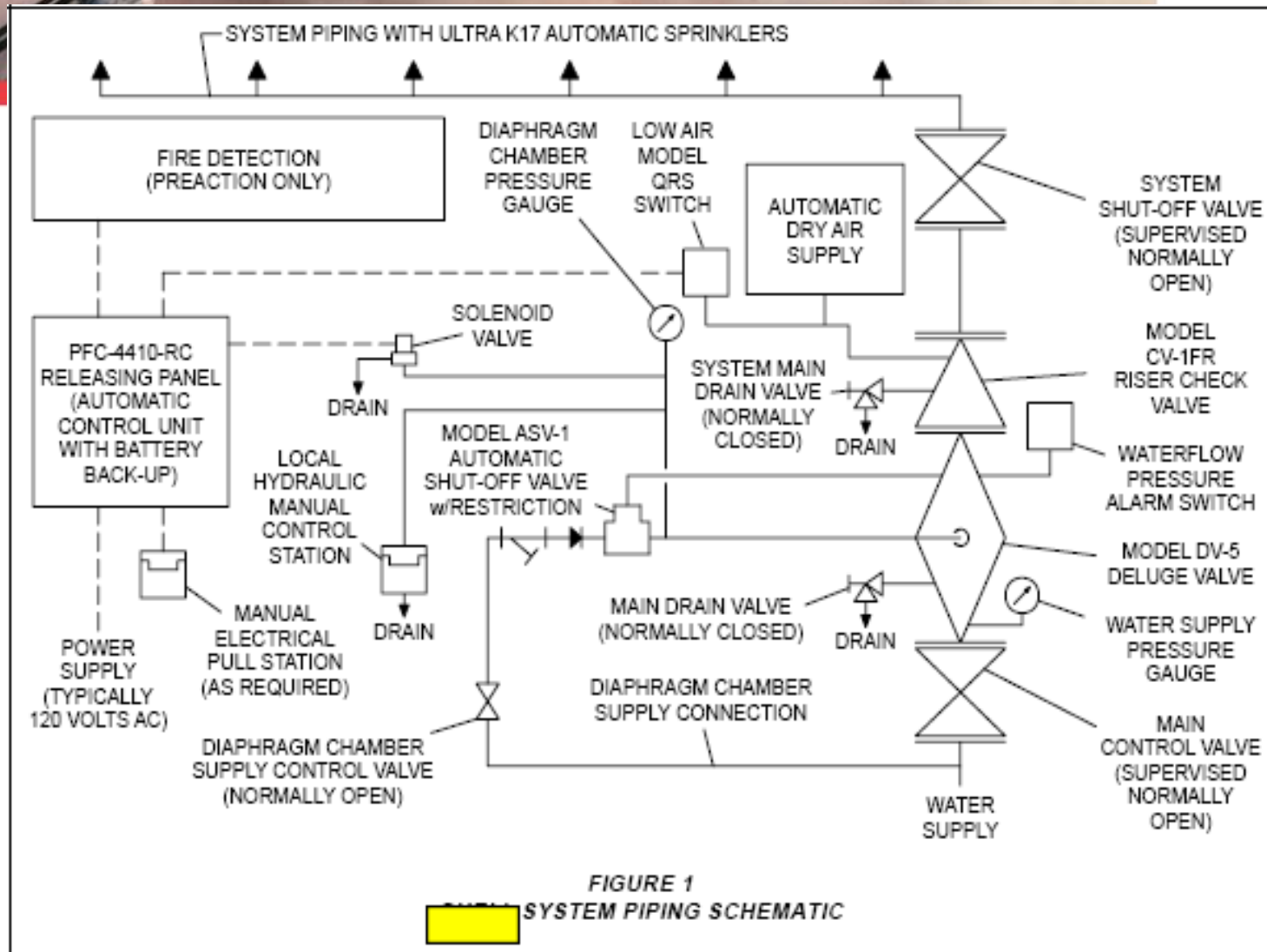

# Water Supplies

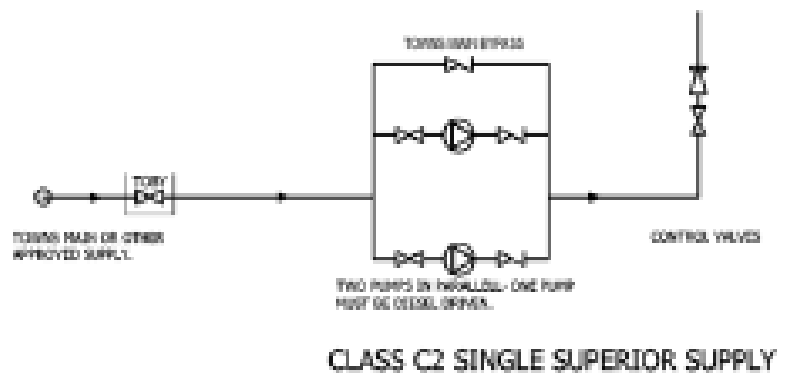

- Dual towns mains gone
- Dual supplies mandated only
  - Seismic zoned High Rise Buildings
  - Large sleeping occupancies
- New Superior Class C supply for non-seismic zoned High Rise Buildings
- Water Storage Volumes changed

## Water Supplies

- DBH formally asked by Committee to review Benefits of Increased Costs for dual water supplies
- All systems need a hydrant demand as per NZS/PAS4509
  - May be reduced if acts as a disincentive to sprinkler

# Hvdrant Allowances

Note requirement to **notify** NZFS if not complied with, if acts as a disincentive to sprinkler protect

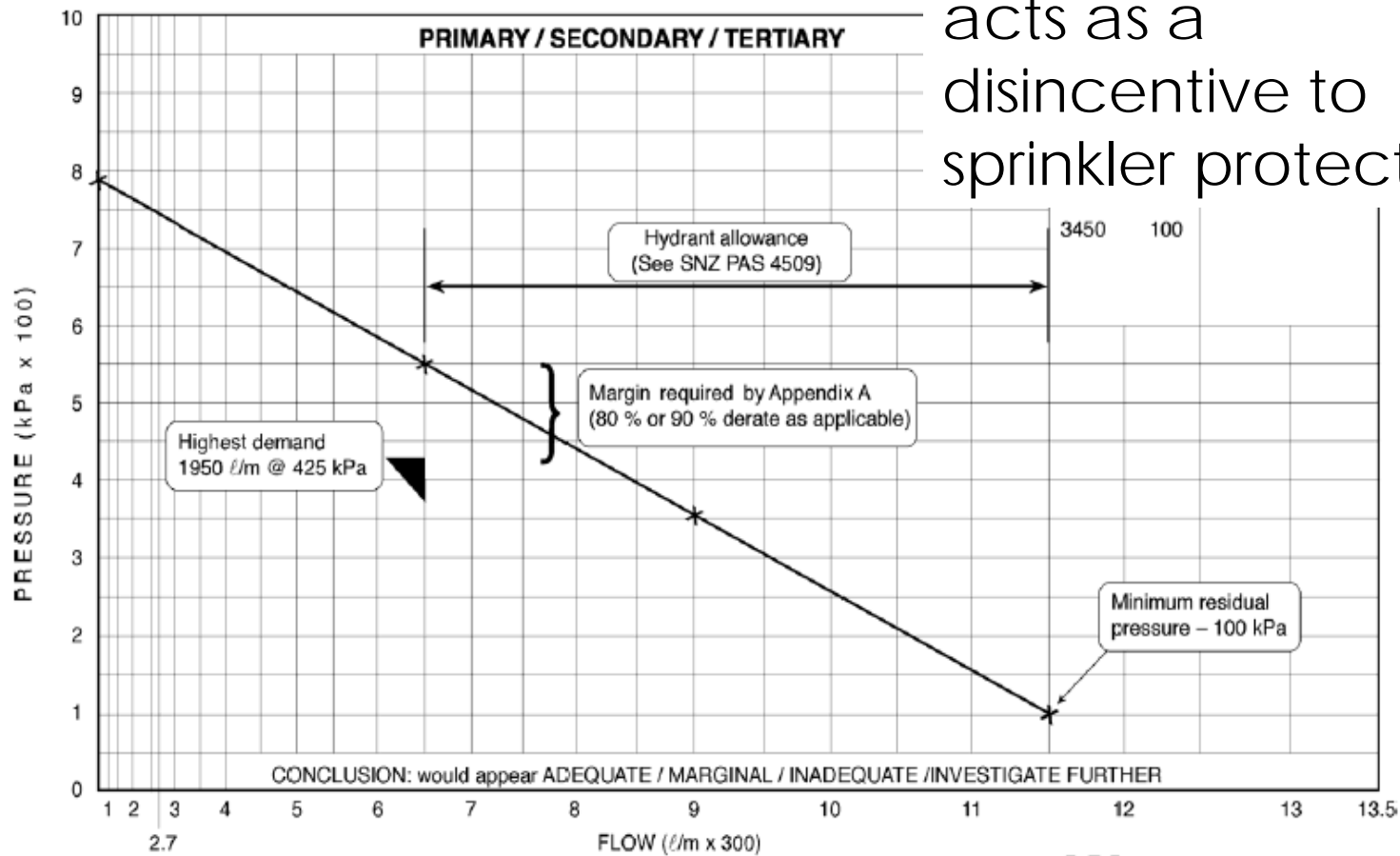

# Other Key Water Supply Changes

- Multiple Fire Service Inlets
  - Spatial and cost savings
- Pump Start arrangement
  - Costs and practicality on large sites
- Seismic vulnerability of towns mains
  - Deferred to DBH on a National Cost vs. benefit issue
- Pump Suction Spatial Issues

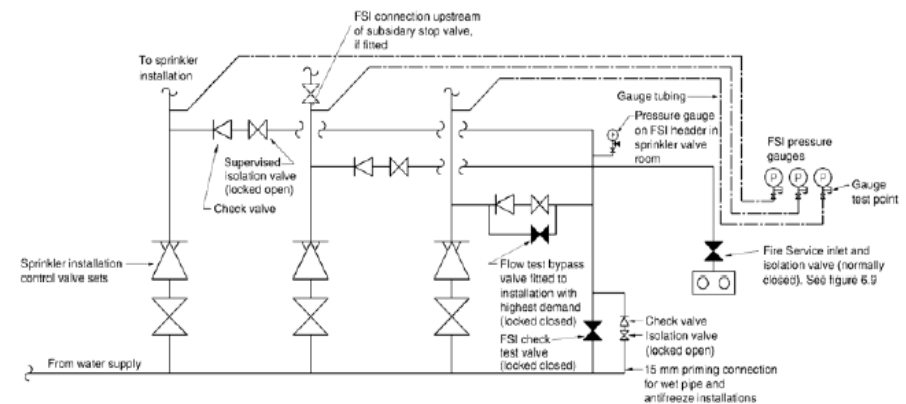

# Pumps – Critical Change

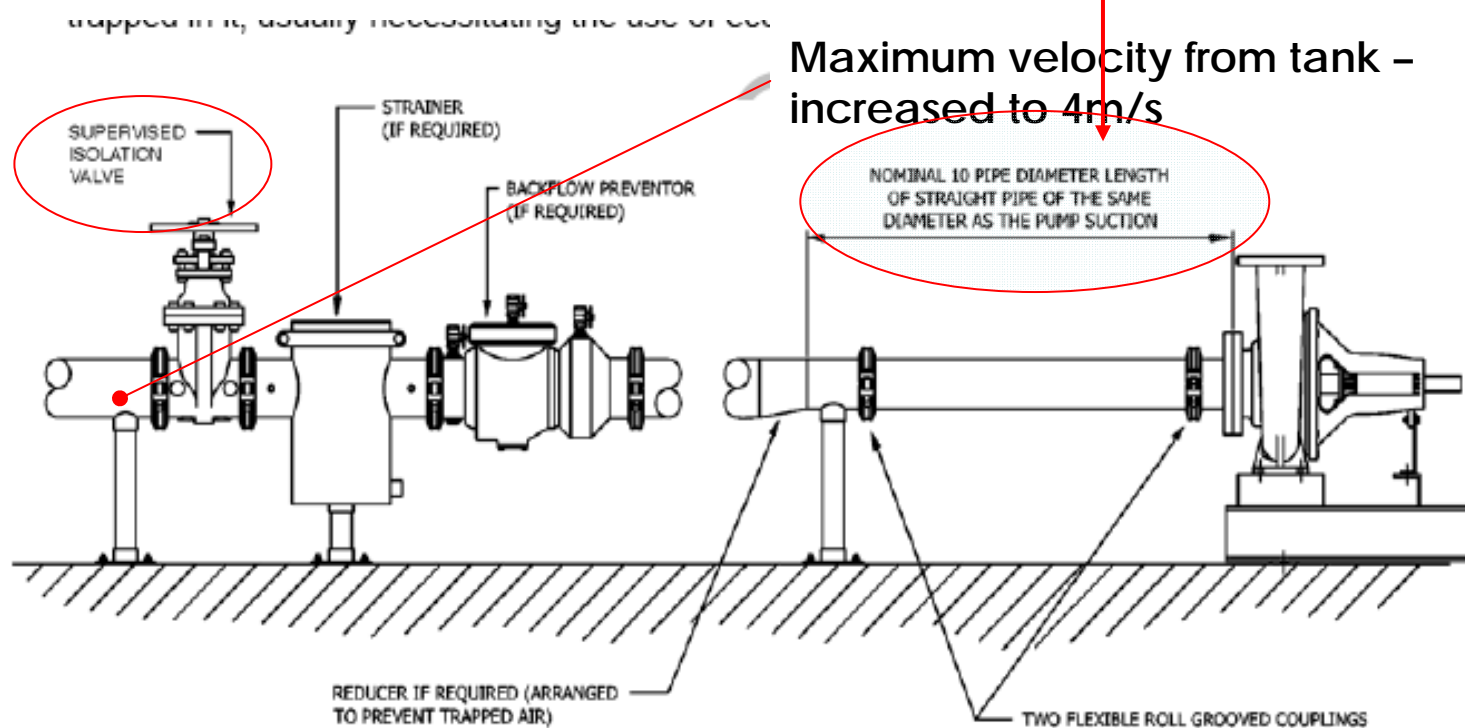

# Fire Service Inlets

- Fire Fighter Protection
  - Need to ensure not endangered by falling glass
  - Same requirements as NZS4510

## 5.1.5

Where the door of the enclosure is on a glazed exterior wall of a multi-storey building, either a verandah or other assembly shall be provided extending at least 1 m in front and 1 m either side of the enclosure to provide protection from falling glass.

## Floor Isolation Valves

- Locate in stairwells, accessible from floor height
- Forget the ladies' toilets
- Forget locked service shafts
- Forget ladder access

# High Ordinary Hazard Spaces

- Maximum Ceiling Height for OH1 and 2 risks
  - 6m
  - Treat as OH3 Risks if greater ceiling heights involved
- OH3S
  - Design requirements subject to Ceiling Heights
  - Based on full scale research for large US Convention Centres
- EHH addressed in part 9
- ELH Occupancies not yet addressed



# Maintenance

- Gauge Schedules
  - Chart in valve house
  - Lists expected gauge readings
  - Allows Testers to identify and report concerns
- Compliance Schedules
  - Requires the designer to prepare a Maintenance Schedule for non-standard systems
  - Provides guidance when a 12A should not be signed
- Design parameters effectively in Public Domain
- Valve tags

# System Components

- Dry Systems
  - Equipment
  - Air Supplies
  - Calculations
- Alternate Wet and Dry Systems
- Types of Sprinklers
  - Esp. EHH
    - Ratings, orifice sizes, CMSA

## Summary

- Much has changed
- Snap shot of key points
- Those involved in detailed design
  - Need to put in hard yards
- FPA/SNZ Seminars?
  - One day general review?
  - One day on Storage?
  - A month or so around publication